

STELLAR AGGRESSOR™

1184-14 Mini OTR



The Aggressor 1184-14 OTR truck comes with many features designed with the user in mind. The 14' all aluminum body is lightweight and dependable to maximize the payload. This versatile tire service body features an abundance of storage and 272 cubic feet of haul space. The floor of the body is made of sturdy aluminum planking, and the hardware is durable stainless steel. The tool compartment doors slide up and in to allow for easy access inside the compartment. Also featured on the 1184-14 OTR body is a left fold-down rack, and optional wheel well lights.

The 1184-14 OTR truck can be equipped with either a model 2200, 3200 or 4500 hydraulic knuckleboom crane. These cranes are designed to handle the largest of farm tires and the smaller sized OTR tires. All are operated by a standard variable speed radio remote control system. Capacity specifications are found on the back of this brochure.



The SHD-66DD direct-driven hydraulic-drive air compressor is mounted on the crane base. This compressor has a 46 CFM at 175 PSI output. The location allows for cool, clean, fresh air intake, and easy maintenance and serviceability. The SHD-66DD carries a 2-year warranty because of these features.

Optional accessories include, hose reels, a 12V trouble light, plastic storage bins and socket racks. The hoses shown are 1/2" x 50' and 3/8" x 50'.

Designed & Manufactured
in the USA

STELLAR
INDUSTRIES INC.

**Mini OTR
Series
1184-14**

STELLAR AGGRESSOR™ 1184-14 Mini OTR

Specifications	2200	3200	4500
Crane Rating	22,000 foot/pounds	32,000 foot/pounds	45,000 foot/pounds
Boom Extension	Hydraulic 32 inches	Hydraulic 32 inches	Hydraulic 32 inches
Max. Horizontal Reach	14 foot-from CL of Crane 17 foot-from CL of Truck	14 foot-from CL of Crane 17 foot-from CL of Truck	14 foot-from CL of Crane 17 foot-from CL of Truck
Rotation	320 degree power (worm gear drive)	290 degree power (worm gear drive)	290 degree power (worm gear drive)
Lifting Capacities (from CL of truck)	3,650 lbs. @ 9 foot 2,750 lbs. @ 11 foot 2,000 lbs. @ 14 foot 1,550 lbs. @ 17 foot	5,000 lbs. @ 9 foot 4,000 lbs. @ 11 foot 2,900 lbs. @ 14 foot 2,200 lbs. @ 17 foot	7,500 lbs. @ 9 foot 5,600 lbs. @ 11 foot 4,100 lbs. @ 14 foot 3,200 lbs. @ 17 foot
Controls	Proportional Radio Control Standard	Proportional Radio Control Standard	Proportional Radio Control Standard
Stowed Height (above truck frame)	65 inches	60 inches	71 inches
Mounting Space Required	24 inches	24 inches	32 inches
Approx. Shipping Weight	1,350 lbs.	1,900 lbs.	2,400 lbs.

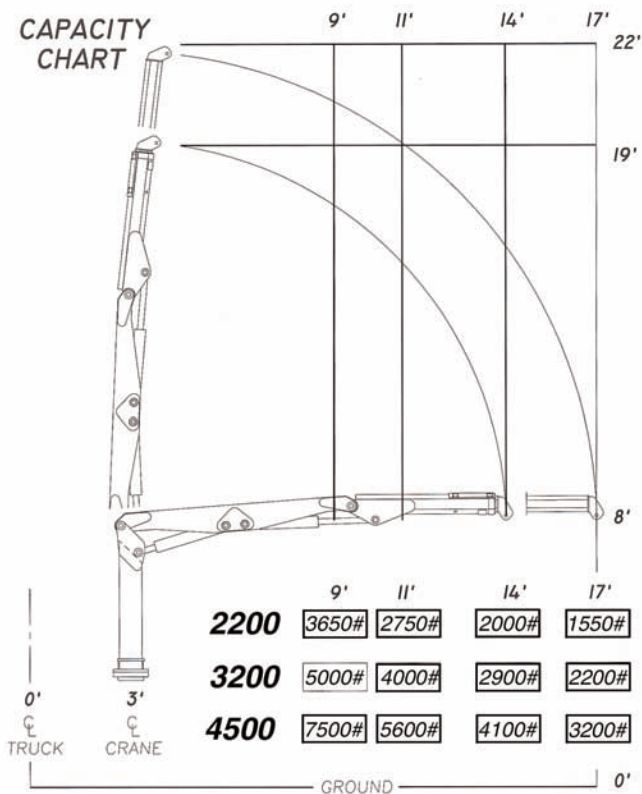

190 State Street
 Garner, Iowa 50438
 1-800-321-3741
 Fax: 641-923-2812
 E-mail: sales@tiretruck.com
 www.tiretruck.com

Designed & Manufactured in the U.S.A.

*Specifications may change without notification.
 Copyright © 2005 Stellar Industries, Inc.